

Curved backdrop assembly.

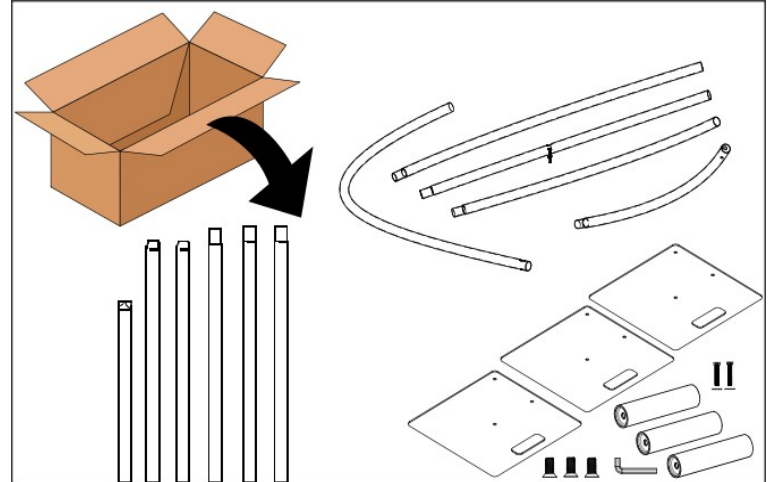
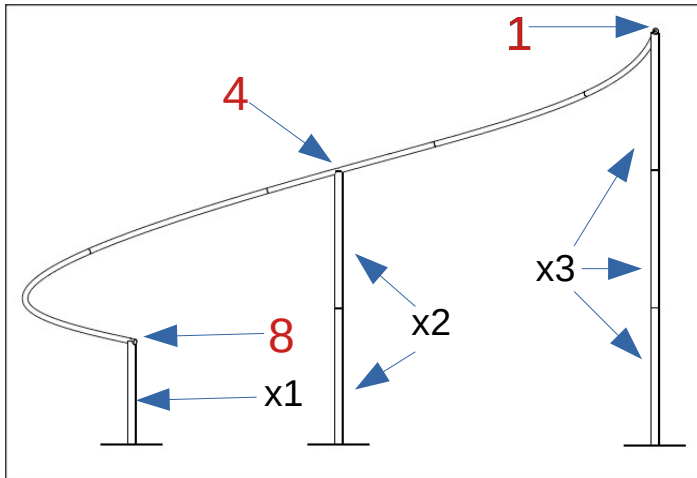

Start by unpacking and layout all pieces

Install pins onto 3 base plates.

Next install uprights onto pins to complete above illustration so you are left with #1, #4, and #8 at the top as described.

Next layout and join together each horizontal pipe section with its respective number until all pieces are securely snapped and locked together.

Lay completed arc upon each upright following illustration above and adjust until sections are relatively lined up. It may helpful to temporarily have a second pair of hands at this point, however it is manageable for one person

Remove nut at #4 of horizontal section and using supplied wrench thread into upright top #4. Repeat using (2) included bolts for connection #1 and #8 insuring washer is placed on inside of pipe between bolt head and pipe wall. Make sure all connections are secure. It may be necessary to re-tighten connections after moving or initial use until pipe sections are fully seated in place.

Washer

